

# HFE21

# MINIATURE HIGH POWER LATCHING RELAY



## Features

- According to IEC 62055-31:UC3
- Strong resistance ability to short circuit current at 6000A
- 120A switching capability
- Heavy load up to 33240VA
- 4kV dielectric strength (between coil and contacts)
- Environmental friendly product (RoHS compliant)
- Outline Dimensions: (52.0 x 43.0 x 22.0) mm

## CONTACT DATA

Contact arrangement	1A, 1B, 1U, 1V
Contact resistance	1A, 1B: 1mΩ (at 1A 24VDC) 1U, 1V: 0.7mΩ (at 1A 24VDC)
Contact material	AgSnO <sub>2</sub>
Contact rating (Res. load)	120A 277VAC/28VDC
Max. switching voltage	440VAC
Max. switching current	120A
Max. switching power	33240VA / 3360W
Mechanical endurance	1 x 10 <sup>5</sup> OPS
Electrical endurance	5000OPS

## CHARACTERISTICS

Insulation resistance	1000MΩ (at 500VDC)	
Dielectric strength	Between coil & contacts	4000VAC 1min
	Between open contacts	2000VAC 1min
Creepage distance	8mm	
Operate time (at nomi. volt.)	20ms max.	
Release time (at nomi. volt.)	20ms max.	
Shock resistance	Functional	98m/s <sup>2</sup>
	Destructive	980m/s <sup>2</sup>
Vibration resistance	10Hz to 55Hz 1.5mm DA	
Humidity	98%RH, 40°C	
Ambient temperature	-40°C to 85°C	
Termination	QC	
Unit weight	Approx. 85g	
Construction	Dust protected	

**Notes:** The data shown above are initial values.

## COIL

Coil power	1 coil latching: 3.0W; 2 coils latching: 6.0W
------------	---

## COIL DATA

at 23°C

Nominal Voltage VDC	Pick-up Voltage VDC	Pulse Duration ms	Coil Resistance x (1±10%) Ω	
6	4.8	100	1 coil latching	13
12	9.6	100		50
24	19.2	100		210
48	38.4	100		860
6	4.8	100	2 coils latching	6.5+6.5
12	9.6	100		25+25
24	19.2	100		105+105
48	38.4	100		430+430



HONGFA RELAY

ISO9001, ISO/TS16949, ISO14001, OHSAS18001, IECQ QC 080000 CERTIFIED

2010 Rev. 1.00

## ORDERING INFORMATION

Type	HFE21 -C 120 /12 -H T 2 -R (XXX)								
Version	A: Type A contact terminal B: Type B contact terminal C: Type C contact terminal D: Type D contact terminal G: Type G contact terminal I: Type I contact terminal J: Type J contact terminal								
Typical sampling resistance	120:120μΩ		150:150μΩ		200:200μΩ			250:250μΩ	
Coil voltage	6, 12, 24, 48VDC								
Contact form	1) H: 1 Form A (Single-contact) SH: 1 Form A (Double-contact)				D: 1 Form B (Single-contact) SD: 1 Form B (Double-contact)				
Contact material	T: AgSnO <sub>2</sub>								
Sort	1: 1 coil latching				2: 2 coils latching				
Polarity	R: Negative polarity				Nil: Positive polarity				
Customer special code									

Notes: 1) H, SH means that relay is on the "reset" status when delivery; D, SD means that relay is on the "set" status when delivery.

## OUTLINE DIMENSIONS AND WIRING DIAGRAM

Unit: mm

### Outline Dimensions

#### Type C contact terminal

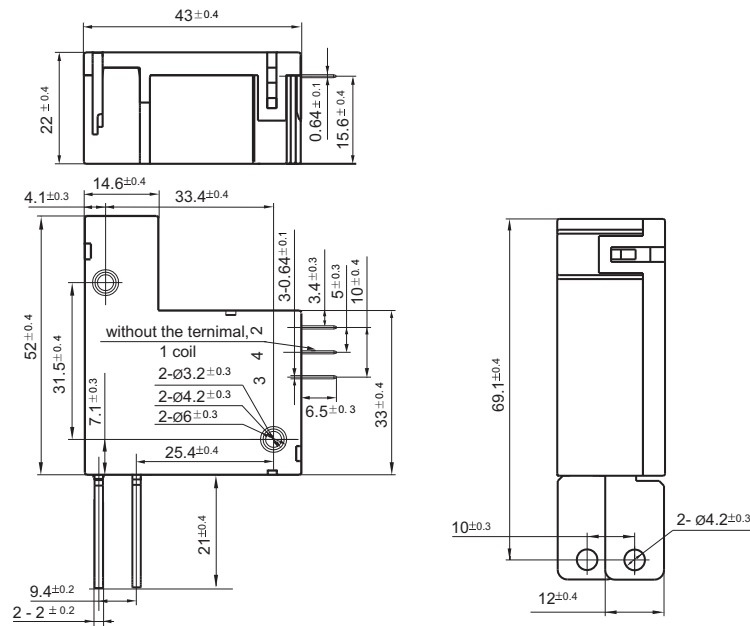

Outline Dimensions

Type A contact terminal

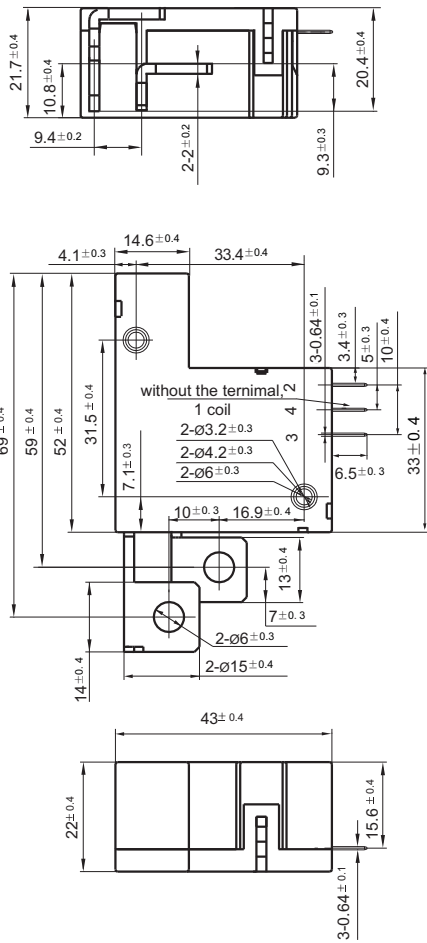

Type B contact terminal

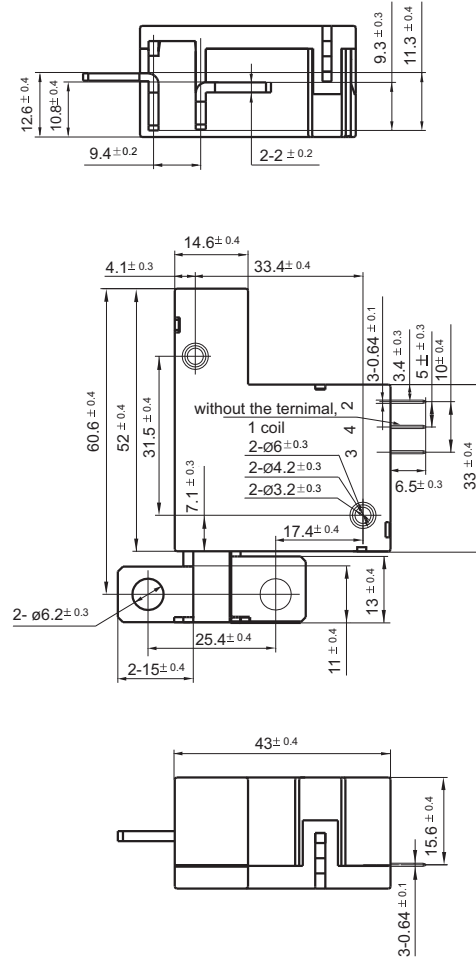

Type C contact terminal with typical sampling resistance

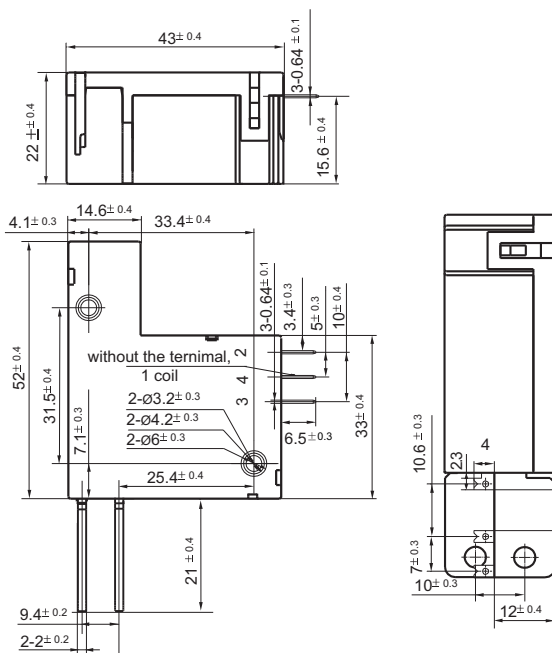

Notes: Type C contact terminal has  $150 \mu\Omega$  such one spec.  
If requiring other typical sampling resistance, special order allowed.

# OUTLINE DIMENSIONS AND WIRING DIAGRAM

Unit: mm

## Outline Dimensions

Type D contact terminal

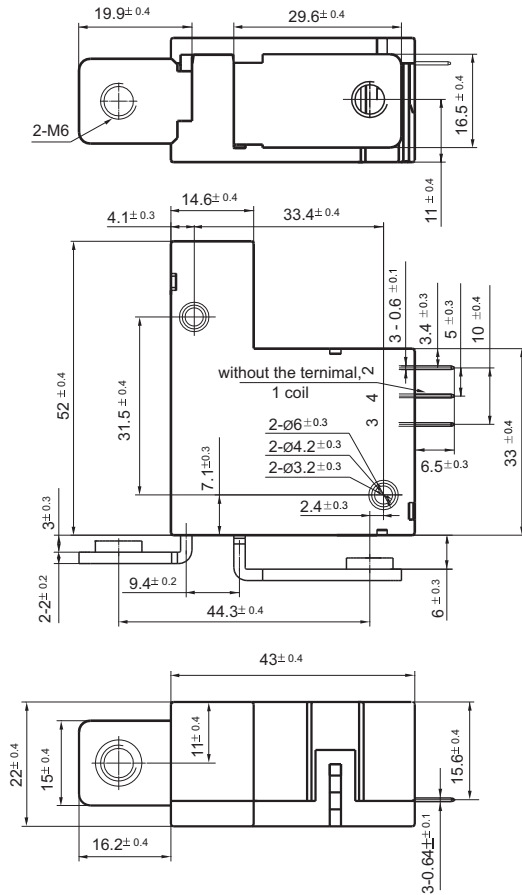

Type D contact terminal with typical sampling resistance

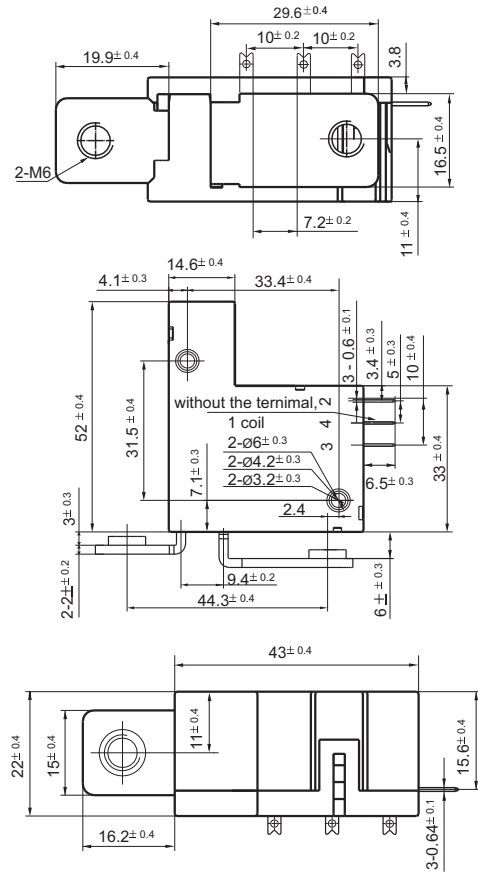

Notes: Type D contact terminal has 120μΩ such one spec. If requiring other typical sampling resistance, special order allowed.

Type G contact terminal

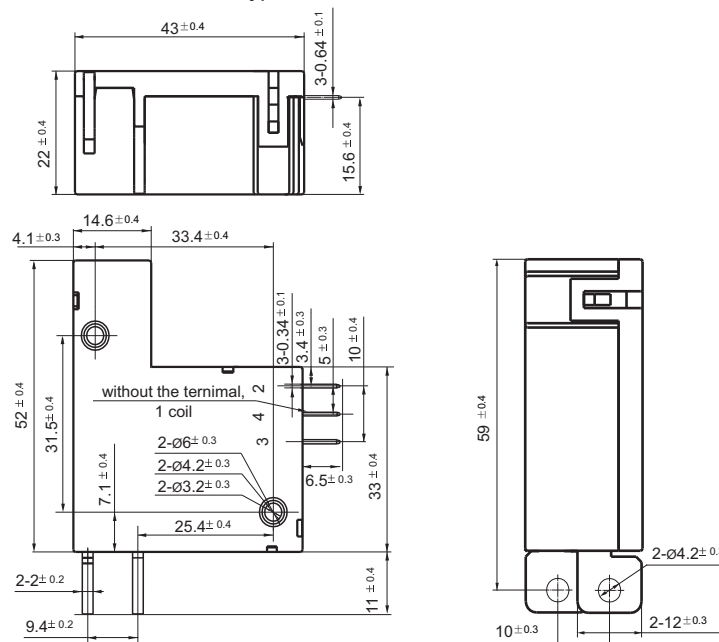



Outline Dimensions

Type J contact terminal

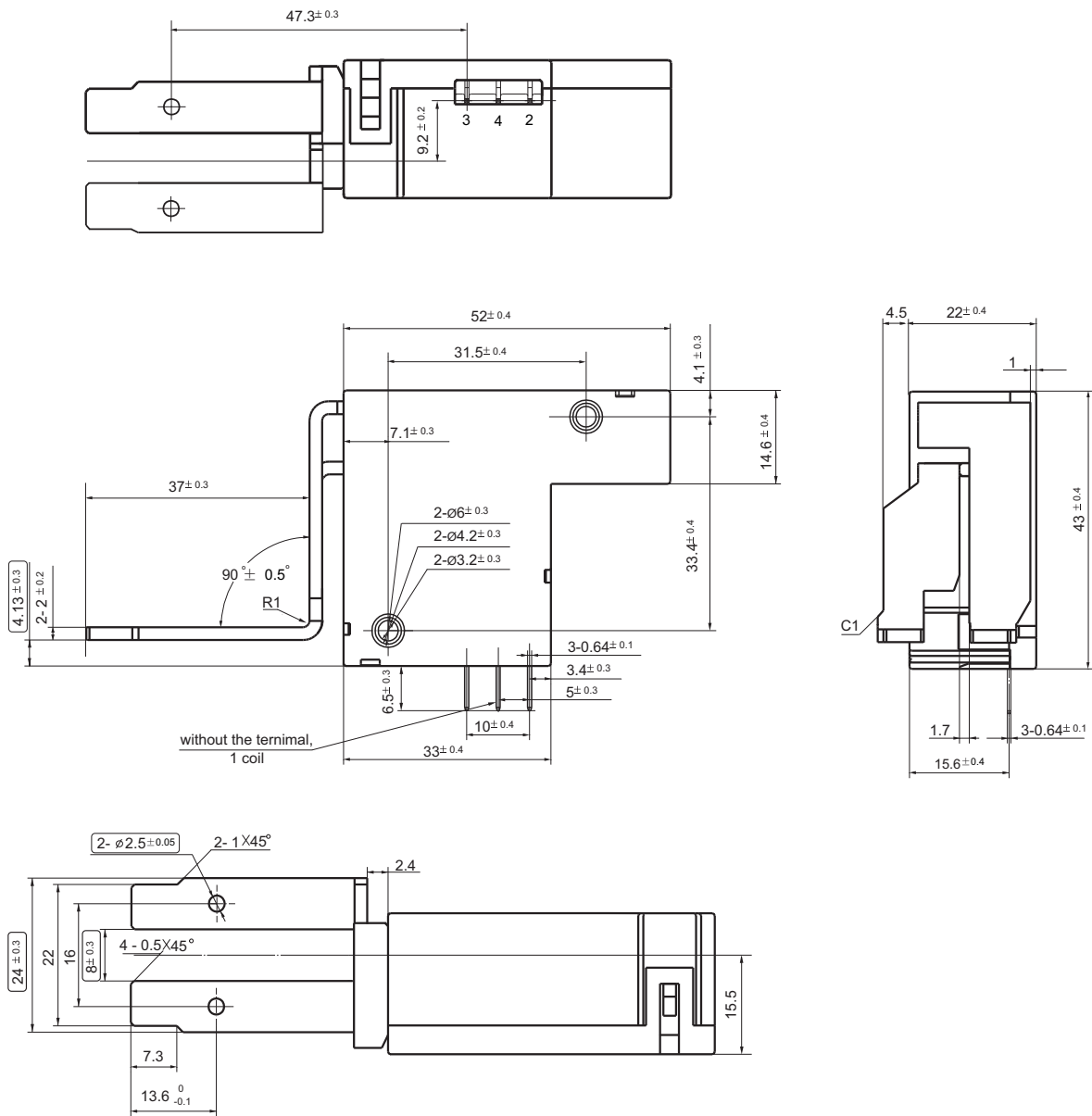

Remark: 1) In case of no tolerance shown in outline dimension: outline dimension  $\leq 1$ mm, tolerance should be  $\pm 0.1$ mm; outline dimension  $> 1$ mm and  $\leq 5$ mm, tolerance should be  $\pm 0.2$ mm; outline dimension  $> 5$ mm, tolerance should be  $\pm 0.4$ mm.

**Coil Wiring Diagram**

Positive polarity

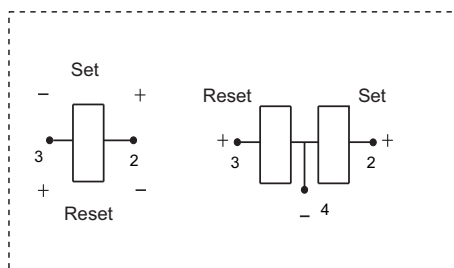

Negative polarity

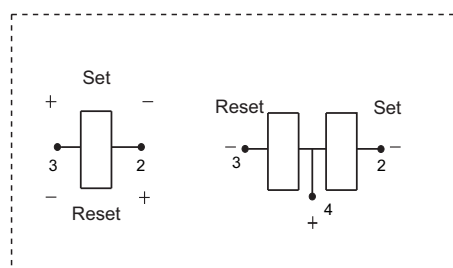

**Notice**

1. Relay is on the "reset" or "set" status when being released from stock, with the consideration of shock risen from transit and relay mounting, relay would be changed to "set" or "reset" status, therefore, when application (connecting the power supply), please reset the relay to "set" or "reset" status on request.
2. In order to maintain "set" or "reset" status, energized voltage to coil should reach the rated voltage, impulse width should be 5 times more than "set" or "reset" time. Do not energize voltage to "set" coil and "reset" coil simultaneously. And also long energized time (more than 1 min) should be avoided.
3. In order to avoid changing operate voltage, products should not be kept in strong magnetic field during transportation, storage and application.

**Disclaimer**

This datasheet is for the customers' reference. All the specifications are subject to change without notice. We could not evaluate all the performance and all the parameters for every possible application. Thus the user should be in a right position to choose the suitable product for their own application. If there is any query, please contact Hongfa for the technical service. However, it is the user's responsibility to determine which product should be used only.